

SPM/SPF

Molded Race, Self-Lubricating



Rod Ends Industrial/ Commercial

Suitable for many light and heavy/medium duty industrial/mechanical motion transfer applications, Tuthill's most popular rod end series, the SPM/SPF Series offers an injection-molded, reinforced nylon raceway design. It delivers low maintenance, self-lubricating characteristics, as well as moisture-resistance properties adding to its overall versatility. Ball and body materials are produced from an economical low carbon steel and are zinc plated with yellow dichromate treatment for extended corrosion resistance (ball is case hardened for extended wear). Suited for applications requiring low friction, low moisture absorption, high wear resistance and/or wide operating temperature ranges. Studded and right or left-handed thread versions are available.

The SPM/SPF Series is just one of many within our broad line of industrial/commercial rod ends. For full product line detail, contact us for a comprehensive catalog or visit www.tuthill.com and download individual product data sheets and other product information.



Description:

SPM/SPF
Industrial/Commercial Rod Ends
Molded Race, Self-Lubricating

Applications:

Numerous mechanical motion transfer devices/applications, including:

- Construction equipment
- Recreational vehicles (ATV's, golf carts, etc.)
- Truck/off highway

Features:

- Nylon molded raceway delivers self-lubricating low friction and moisture-resistant performance
- Good wear resistance
- Design allows for control of breakaway torque, adding to its application versatility
- Can be used in a wide range of temperatures: -30°F — 220°F (-34°C — 104°C)
- Offered in studded and right or left-handed versions
- Special custom alloy construction available
- Custom assemblies can be built to your specifications
- Meets SAE spec J1120

Other Related Products:

- MJ-M/FJ-M Metric Molded Race

SPM/SPF

Molded Race,
Self-Lubricating

Material

Ball

- Low Carbon Steel Case Hardened
- Zinc Plated, Yellow Dichromate Treated

Body

- Low Carbon Steel
- Zinc Plated, Yellow Dichromate Treated

Race

- Molded Self-Lubricating Reinforced Nylon

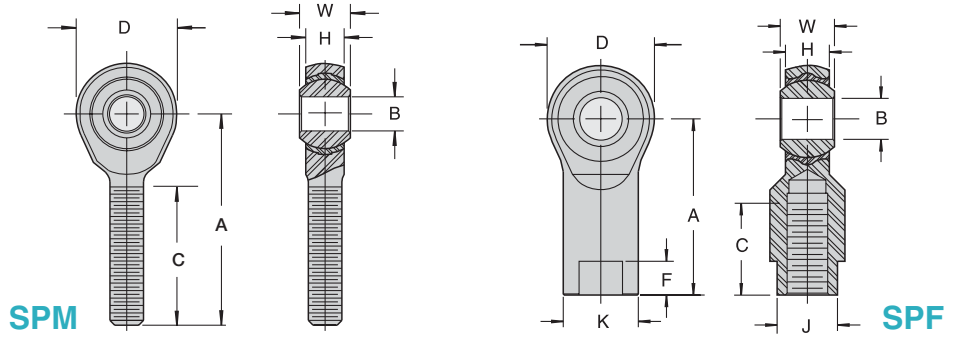

SPM Male Chart

Part Number		B +.0020 -.0000	W ±.005	H REF	A ±.015	D ±.015	REF	C ±.060	UNF-2A	Ultimate Radial Static Load Capacity (Pounds)	Weight (Pounds)
Right Hand	Left Hand	Ball Bore	Ball Width	Housing Width	Centerline Length	Head Diameter	Ball Diameter	Thread Length	Thread Size		
SPM3	SPML3	.1900	.312	.250	1.250	.625	.438	.750	10-32	1210	.023
SPM4	SPML4	.2500	.375	.281	1.562	.750	.516	1.000	1/4-28	2470	.040
SPM5	SPML5	.3125	.437	.344	1.875	.875	.625	1.250	5/16-24	2740	.071
SPM6	SPML6	.3750	.500	.406	1.937	1.000	.719	1.250	3/8-24	4210	.107
SPM7	SPML7	.4375	.562	.437	2.125	1.125	.812	1.312	7/16-20	5350	.148
SPM8	SPML8	.5000	.625	.500	2.437	1.312	.938	1.500	1/2-20	6430	.232
SPM10	SPML10	.6250	.750	.562	2.625	1.500	1.125	1.625	5/8-18	8300	.364
SPM12	SPML12	.7500	.875	.687	2.875	1.750	1.312	1.750	3/4-16	10900	.568

SPF Female Chart

Part Number		B +.0020 -.0000	W ±.005	H REF	A ±.015	D ±.015	K ±.015	J ±.015	F ±.030	REF	C ±.060	UNF-2B	Ultimate Radial Static Load Capacity (Pounds)	Weight (Pounds)
Right Hand	Left Hand	Ball Bore	Ball Width	Housing Width	Centerline Length	Head Diameter	Shank Diameter	Wrench Flat Width	Wrench Flat Length	Ball Diameter	Thread Length	Thread Size		
SPF3	SPFL3	.1900	.312	.250	1.062	.625	.406	.312	.406	.438	.562	10-32	1210	.036
SPF4	SPFL4	.2500	.375	.281	1.312	.750	.469	.375	.281	.516	.750	1/4-28	2470	.059
SPF5	SPFL5	.3125	.437	.344	1.375	.875	.500	.437	.281	.625	.750	5/16-24	2740	.077
SPF6	SPFL6	.3750	.500	.406	1.625	1.000	.687	.562	.312	.719	.937	3/8-24	4100	.146
SPF7	SPFL7	.4375	.562	.437	1.812	1.125	.750	.625	.625	.812	1.031	7/16-20	5350	.192
SPF8	SPFL8	.5000	.625	.500	2.125	1.312	.875	.750	.375	.938	1.187	1/2-20	6430	.313
SPF10	SPFL10	.6250	.750	.562	2.500	1.500	1.000	.875	.500	1.125	1.500	5/8-18	8300	.464
SPF12	SPFL12	.7500	.875	.687	2.875	1.750	1.125	1.000	1.000	1.312	1.562	3/4-16	10900	.672

Chart Notes: This series is also available in a studded configuration. Specify by adding "S" to suffix. Example: SPF8S

Studded Dimensions

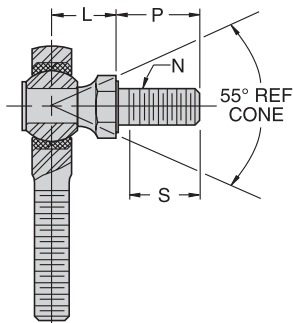

Rod End Bore Size	L REF	P ±.030	S Min. Thread Length	N Thread Size UNF-2A
3/16"	.437	.438	.375	10-32
1/4"	.469	.563	.500	1/4-28
5/16"	.531	.688	.594	5/16-24
3/8"	.625	.875	.781	3/8-24
7/16"	.844	1.062	.937	7/16-20
1/2"	.875	1.125	1.000	1/2-20
5/8"	1.000	1.125	1.000	5/8-18
3/4"	1.187	1.812	1.625	3/4-16

Product Selector Guide

- Rod Ends — Industrial/Commercial
- Rod Ends — Precision/Heavy Duty
- Spherical Bearings
- Ball Joints
- Swivels
- Clevises/Safety Fasteners/Pins

Linking Motion
& Control...
The Tuthill
Solution



2110 Summit Street
New Haven, Indiana USA 46774
Tel 260 749-5105 Fax 260 493-2387
www.tuthill.com

• Please refer to the Warning statement and appropriate installation usage information in the Tuthill Technical/Application Data brochure
• For application assistance/technical questions, please contact (titech@tuthill.com) or phone (260-749-5105)