

R-G

Steel Housing, Staked Design
with Rubber Grommet



Ball Joints

The Tuthill R-G Series (SAE J490/Type G/Style 2) offers a widely used and economic metal to metal ball joint design. Ball stud and body are produced from low carbon steel and the ball stud is heat treated. All parts are zinc plated and treated with a yellow dichromate for corrosion resistance and consistent appearance. The precision heat treated ball is inserted into the shell and a precise crimping process retains the ball while providing sufficient movement of the ball stud without excessive play. A rubber grommet seal provides for durable contaminant protection. Right and left-handed threads (for metric sizes — consult factory) are available in a variety of configurations.

The R-G Series is just one of many within our broad line of ball joints. For full product line detail, contact us for a comprehensive catalog or visit www.tuthill.com and download individual product data sheets and other product information.



Description:

R-G Series Ball Joints
Steel Housing, Staked Design
with Rubber Grommet

Applications:

- Various integral ball joint applications, including:
- Lawn and garden equipment
 - Construction
 - Industrial equipment

Features:

- Steel body and ball stud "staked" design offers an economical solution to medium to heavy-duty ball joint applications
- Ball stud is case hardened for extended wear life
- Rubber grommet provides a durable seal against contaminants
- Can be used in a wide range of temperatures:
-30°F — 250°F
(-34°C — 121°C)
- Custom sizes and assemblies can be built to your specifications, including:
 - male to male or female to female
 - right or left-handed threads
- Many metric sizes available — consult factory
- Meets SAE specification J490 (Type G/Style 2)

Other Related Products:

- P Hard Plastic Housing with Steel Ball Stud
- SR-G Hardened Steel Housing, Retaining Ring with Rubber Grommet
- S/SS/SC Quick Disconnect with Spring or Spring Clip

R-G

Steel Housing, Staked Design
with Rubber Grommet

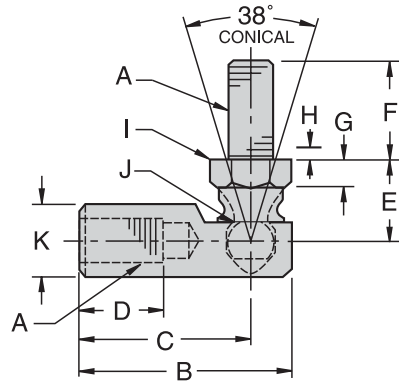

Material

Ball Stud

- Low Carbon Steel, Case Hardened for Extended Wear Life
- Zinc Plated, Yellow Dichromate Treated

Body

- Low Carbon Steel
- Zinc Plated, Yellow Dichromate Treated

Linking Motion
& Control...
The Tuthill
Solution



R-G CHART

Part Number	A	B	C	D	E	F	G	H	I	J	K	W.F. Width	W.F. Length	Tensile & Shear Strength (Pounds)	Force to Remove Ball Stud (Pounds)	
Right Hand	Left Hand	UNF	±.020	±.020	MIN	±.020	±.020	REF	REF	REF	REF	REF	REF			
R103G	R103GLH	10-32	1.156	.875	.469	.359	.438	.094	.062	.312	.177	.375	.312	.250	295	690
R107G	R107GLH	1/4-28	1.219	.969	.500	.469	.562	.125	.094	.375	.193	.437	.375	.281	882	1,005
R108G	R108GLH	5/16-24	1.406	1.125	.562	.531	.687	.156	.094	.437	.232	.500	.437	.281	1,587	1,282
R109G	R109GLH	3/8-24	1.687	1.375	.750	.687	.875	.187	.094	.500	.287	.625	.500	.312	2,437	1,700
R110G	R110GLH	7/16-20	2.375	1.937	1.125	.875	1.125	.250	.125	.625	.412	.750	.625	.375	3,390	2,700
R111G	R111GLH	1/2-20	2.375	1.937	1.125	.875	1.125	.250	.125	.625	.412	.750	.625	.375	3,390	2,700

Chart Notes: 1. Ball Joint can be ordered without the grommet by dropping the "G" suffix. Example: R108LH
2. R103G size is supplied with a wrap around grommet, not shown.

Product Selector Guide

- Rod Ends — Industrial/Commercial
- Rod Ends — Precision/Heavy Duty
- Spherical Bearings
- Ball Joints
- Swivels
- Clevises/Safety Fasteners/Pins



TUTHILL
Controls Group

2110 Summit Street
New Haven, Indiana USA 46774
Tel 260 749-5105 Fax 260 493-2387
www.tuthill.com

• Please refer to the Warning statement and appropriate installation usage information in the Tuthill Technical/Application Data brochure
• For application assistance/technical questions, please contact (tlttech@tuthill.com) or phone (260-749-5105)