

P

Hard Plastic Body with Steel Ball Stud



Ball Joints

Suitable for many lighter-duty applications such as engine controls, electronic devices, and a wide range of applications requiring low force mechanical actuators, the Tuthill P Series offers our most economical ball joint design. P Series ball joints are effective in corrosive environments. The ball stud is produced from low carbon steel that is zinc plated and yellow dichromate treated for extended corrosion resistance. The body is hard molded thermo plastic and offers self-lubricating and wear resistance benefits. The assembly also offers the ability to quickly disconnect the ball stud from the housing to improve ease-of-maintenance.

The P Series is just one of many within our broad line of ball joints. For full product line detail, contact us for a comprehensive catalog or visit www.tuthill.com and download individual product data sheets and other product information.



Description:

P Series Ball Joints
Hard Plastic Body with
Steel Ball Stud

Applications:

Lighter duty linkage applications, including:

- Agricultural
- Lawn and garden equipment
- Engine controls
- Racing

Features:

- Plastic body and a steel ball stud design offers our most basic construction and cost-effective ball joint model
- Plastic body offers self-lubrication, wear resistance benefits
- Quick disconnect assembly provides easier maintenance
- Can be used in a wide range of temperatures:
-30°F — 220°F
(-34°C — 104°C)

Other Related Products:

- SR-G Hardened Steel Housing, Retaining Ring with Rubber Grommet
- R-G Steel Housing, Staked Design with Rubber Grommet
- S/SS/SC Quick Disconnect with Spring or Spring Clip

P

Hard Plastic Body
with Steel Ball Stud

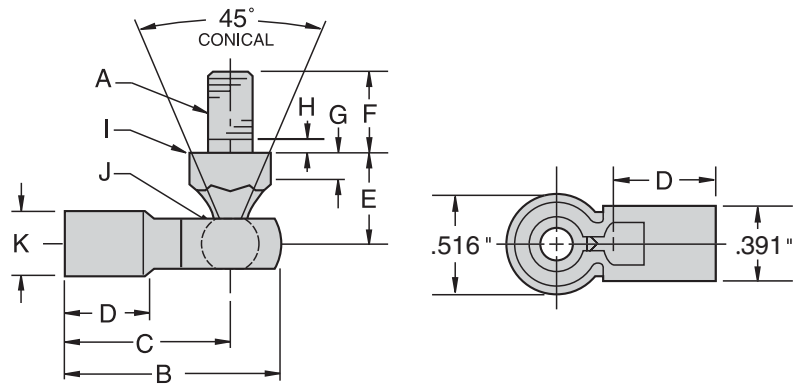

Material

Ball Stud

- Low Carbon Steel
- Zinc Plated, Yellow Dichromate Treated

Body

- Hard Thermo-Molded Plastic
- Wear Resistant

Linking Motion
& Control...
The Tuthill
Solution



P CHART

Part Number	A	B	C	D	E	F	G	H	I	J	K	Ball Diameter REF
	UNF	±.030	±.030	REF 7/8	±.020	±.020	REF	REF	REF	REF	REF	REF
P103S	10-32	.875	.656	.437	.437	.437	.125	.062	.312	.125	.312	.229
P103L	10-32	1.109	.875	.594	.437	.437	.125	.062	.375	.156	.312	.309
P107	1/4-28	1.109	.875	.375	.437	.562	.125	.062	.375	.156	.312	.309
P103BL*	10-32	—	—	—	.437	.437	.125	.062	.375	.156	—	.309
P103HL**	10-32	1.109	.875	.594	—	—	—	—	—	—	.312	—

Chart Notes: *Ball Stud only **Body only

Product Selector Guide

- Rod Ends —
Industrial/Commercial
- Rod Ends —
Precision/Heavy Duty
- Spherical Bearings
- Ball Joints
- Swivels
- Clevises/Safety Fasteners/Pins



2110 Summit Street
New Haven, Indiana USA 46774
Tel 260 749-5105 Fax 260 493-2387
www.tuthill.com

• Please refer to the Warning statement and appropriate installation usage information in the Tuthill Technical/Application Data brochure
• For application assistance/technical questions, please contact (tjgtech@tuthill.com) or phone (260-749-5105)